

28 July 2025

## Research on Automatic Docking System of LNG Marine Loading Arm Based on Machine Vision

### What is this technology?

An **Automatic Docking System for LNG Marine Loading Arms**, which leverages **machine vision, deep learning, and motion control** to automate the process of connecting LNG (Liquefied Natural Gas) loading arms to ship flanges.

- **Two-Step Positioning:** (a) **Coarse Positioning:** Uses a pan-tilt camera with YOLOv5 (You Only Look Once object detection algorithm) to detect the flange and estimate its approximate 3D coordinates based on monocular distance measurement. (b) **Fine Positioning:** Combines high-resolution industrial cameras and ultrasonic sensors for precise detection. Edge detection (Canny operator) and ellipse fitting algorithms calculate the exact center coordinates of the flange.
- **Machine Vision:** (a) YOLOv5 for real-time flange detection. (b) Adaptive thresholding and **Hough circle detection** for complete flange images. (c) **Projection Invariant Feature Number (CN)** for ellipse fitting of incomplete flange images.
- **Kinematic Modeling:** (a) Uses **modified D-H (Denavit-Hartenberg) parameters** to model the LNG loading arm's kinematics, enabling inverse kinematics for trajectory planning.
- **Path Planning:** Improved RRT (Rapidly-exploring Random Tree) algorithm to plan collision-free paths, optimized for speed and efficiency.
- **Control System:** **PID (Proportional-Integral-Derivative) dual-loop control** (position and velocity loops) to precisely move the hydraulic-driven loading arm along the planned trajectory.

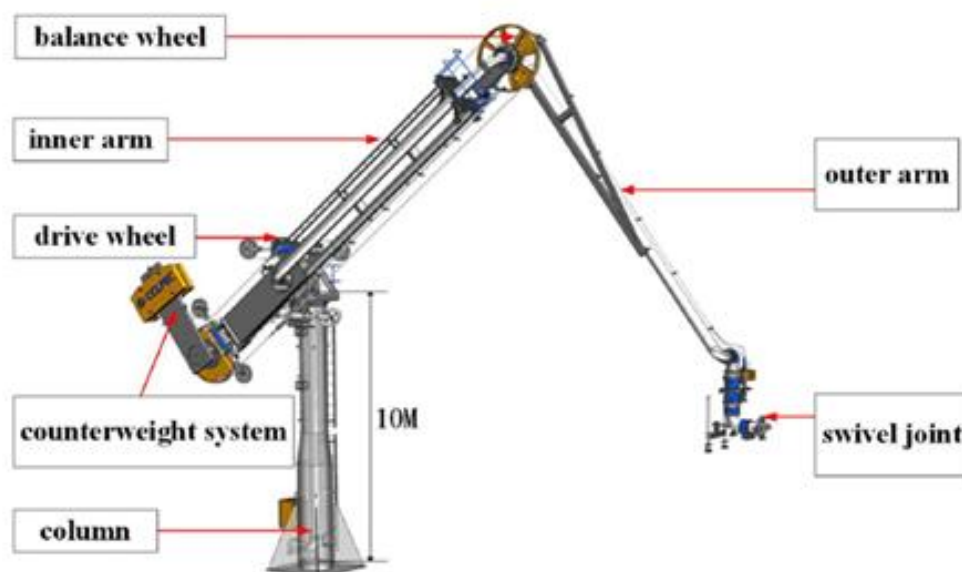

## What does this technology mean?

The Automatic Docking System for LNG Marine Loading Arms represents a transformative advancement for the maritime industry, particularly in LNG (Liquefied Natural Gas) shipping and port operations.

- **Enhanced Safety:** (a) **Eliminates manual intervention:** Reduces risks for workers who previously had to guide the loading arm near high-pressure, cryogenic (-162°C) LNG pipelines. (b) **Mitigates human error:** Automated precision docking minimizes accidents caused by misalignment or operator fatigue. (c) **Complies with ISO 16904:2016:** Ensures adherence to international safety standards for LNG transfer equipment.
- **Operational Efficiency:** (a) **Faster docking:** Completes the process in under 15 minutes (vs. slower manual methods), reducing ship turnaround time. (b) **High accuracy:** Sub-centimeter precision (average 5.80 mm error) ensures reliable connections, avoiding leaks or delays. (c) **24/7 readiness:** Less dependent on human operators, enabling operations in low-visibility or adverse weather conditions.
- **Cost Saving:** (a) **Reduces labor costs:** Fewer personnel needed for hazardous docking tasks. (b) **Minimises downtime:** Faster, more reliable docking cuts idle time for ships and port infrastructure. (c) **Avoids costly incidents:** Prevents spills or equipment damage due to manual misalignment.
- **Sustainability & Compliance:** (a) **Supports clean energy transition:** LNG is a critical bridge fuel for decarbonizing shipping (e.g., IMO 2030/2050 targets). Efficient transfer systems are vital for scaling LNG bunkering. (b) **Reduces fugitive emissions:** Precise automation limits methane leaks during connection/disconnection.

**Link to the article:** [Research on Automatic Docking System of LNG Marine Loading Arm Based on Machine Vision](#)

*Insights by: Song Hanyu, Manager, SMI*

Connect with us



[smi@maritimeinstitute.sg](mailto:smi@maritimeinstitute.sg)